



**810101, 810102, 810103
810104, 810105**

IP-01 SERIES

**1:1 RATIO TRANSFER PUMP
OPERATIONS MANUAL**



IPM, INC.

Manufactured by: International Pump Manufacturing, Inc.

IP-01 series

1:1 RATIO TRANSFER PUMPS

OPERATIONS MANUAL and PARTS IDENTIFICATION DRAWINGS

This manual contains IMPORTANT WARNINGS and INSTRUCTIONS. Read and retain for future reference.

INTERNATIONAL PUMP MANUFACTURING, INC.
3107 142nd Avenue E Suite 106,
Sumner, WA 98390
U.S.A.
TEL: (253) 863 2222
FAX: (253) 863 2223
Website : www.ipmpumps.com

For Technical Service Call Your Local Distributor

Copyright 2004 by: International Pump Mfg, Inc.

WARNING: The equipment described herein must only be operated or serviced by properly trained individuals thoroughly familiar with the operating instructions, mechanics and limitations of the equipment.

Notice: All statements, information and data given herein are believed to be accurate and reliable but are presented without guarantee, warranty or responsibility of any kind expressed or implied. Statements or suggestions concerning possible use of IPM equipment are made without representation or warranty that any such use is free of patent infringement, and are not recommendations to infringe any patent. The user should not assume that all safety measures are indicated or that other measures may not be required.

TABLE OF CONTENTS

1.0	SAFETY WARNINGS	4
2.0	INSTALLATION	8
2.1	Installation procedures	9
2.2	Additional mounting configurations	10
3.0	OPERATIONS	12
3.1	Working principle of transfer pump fluid section	12
3.2	Start-up and adjustment of transfer pump	13
3.3	Shut-down procedure	13
3.4	Daily maintenance check	14
3.5	Disassembly procedure	14
3.6	Assembly procedure	18
4.0	IPM PUMP IDENTIFICATION LIST	19
5.0	PARTS DIAGRAMS	20
4.1	Parts drawing/parts list for 810101 (Air section)	20
4.2	Parts drawing/parts list for 810101 (Fluid section)	21
4.3	Parts drawing/parts list for 810102 (Air section)	22
4.4	Parts drawing/parts list for 810102 (Fluid section)	23
4.5	Parts drawing/parts list for 810103 (Air section)	24
4.6	Parts drawing/parts list for 810103 (Fluid section)	25
4.7	Parts drawing/parts list for 810104 (Air section)	26
4.8	Parts drawing/parts list for 810104 (Fluid section)	27
6.0	REPAIR KITS	28
7.0	TROUBLE SHOOTING	29
8.0	TECHNICAL SPECIFICATIONS	30
9.0	WARRANTY AND DISCLAIMER	33

1.0 SAFETY WARNINGS

Please read and observe all warnings contained in this operations manual before making any attempt to operate the equipment.

Warning

To reduce the risk of static sparking or splashing fluid in the eyes or on the skin, follow the ***Pressure Relief Procedure*** before flushing.

For your safety, read the ***Fire or Explosion Hazard*** before flushing and follow all the listed recommendations.

Misuse of equipment

Misuse of equipment can cause serious bodily injury. Use the equipment only for its intended purpose and do not attempt to modify it in any way. Care should be taken to prevent over pressurization of the pump, hose lines and accessories connected to it. Use only IPM designated parts for re-building or repairing this equipment. Use the pump only with compatible fluids. Improper use of this equipment could result in fluid being sprayed on the skin or in the eyes of user, serious bodily injury, property damage, fire or explosion.

Daily maintenance inspection should be made on pumps and equipment and all worn or damaged parts should be re-placed immediately. Do not use pumps, components or hose lines as leverage to move equipment to avoid damage and injury.

Do not alter this equipment as doing so could cause it to function incorrectly and/or cause serious injury. Altering this equipment in any way will also void any and all warranty guarantees from the manufacturer.

Material & fluid compatibility

Always ensure the chemical compatibility of the fluids and solvents used in the fluid section of these pumps, hoses other components. Check the chemical manufacturer's data sheets and specification charts before using fluids or solvents in this pump to ensure compatibility with pumps, inner hose lining and outer hose covering.

Pressurized hoses

Because the hoses are pressurized they can present a danger should the fluid escape due to damage, worn parts or general miss-use. Escaping fluid can splash or spray operator, causing serious bodily injury and/or damage to equipment and property. Ensure that the hoses do not leak or rupture due to wear, misuse or damage.

Before each use, ensure that the fluid couplings are tight and all clips/pins/plugs are secured. Inspect the entire length of hose for wear, cuts, abrasions, bulging cover and/or loose connections. These conditions may cause the hose to fail and result in splashing or spraying of chemicals on the skin or in the eyes of operator and cause serious injury and/or property damage.

Pressure specification

The maximum working pressure of this equipment for fluids and air is *180 psi (12.5bar)*. Ensure all equipment and accessories used with this pump are rated to withstand the maximum working pressure of this pump. Never exceed the maximum working pressure of the pump, hose lines or any other components attached to the pump itself.

Procedure for pressure relief

In order to avoid the risk of serious injury to operators from splashing/spraying chemicals, the following safety procedures should be used. This procedure should be used when shutting down the pump, performing general maintenance, repairing a pump or other components of the system, replacing components or when pumping operation is ceased.

1. Close the air valve to the pump.
2. Use the air bleed down valve (see INSTALLATION, page 8) to relieve the air pressure in the system.
3. Relieve the fluid pressure by holding a grounded metal pail in contact with the metal part of the fluid dispense valve and slowly opening the valve.
4. With a container ready to catch the fluid, open the drain valve (see INSTALLATION, page 8).
5. It is a good practice to leave the drain valve open until it is time to dispense fluid again.

If you are unsure that the fluid pressure has been relieved due to a blockage in a component or a hose, carefully relieve the pressure by carefully loosening the hose end coupling to allow the fluid pressure to escape slowly. After the pressure has been relieved, the fitting can then be removed and any blockages removed.

Flush the pump before initiating operation

1. The pump is tested with lightweight DOP oil, which is left in to protect the pump parts. If the fluid you are pumping may become contaminated by oil, flush oil from pump with a compatible solvent before use. Follow the flushing instructions below.
2. When pumping fluids that set up or solidify, flush the system with a compatible solvent as often as necessary to remove build-up of solidified chemicals in the pump or hoses.
3. If the pump is being used to supply a circulating system, allow the solvent to circulate through the entire system for at least 30 minutes every 48 hours or more often if necessary to prevent settling and solidification of chemicals.
4. Always fill the wet-cup 1/2 full of throat seal liquid (TSL) or compatible solvent to keep the fluid from drying on the displacement rod and damaging pump throat packing.
5. Lubricate the throat packing frequently, when you are pumping a non-lubricating fluid or are shutting down for more than one day.

Shut down & care of pump

For overnight shut down, follow the Pressure Relief Procedure. *Always stop the pump at bottom of the stroke to prevent the fluid from drying on the exposed displacement rod and damaging the throat packing.*

Hazards from fire or explosion

Hazards exist where sparks can ignite vapors or fumes from combustible chemicals or other hazardous conditions exist such as explosive dust, etc. These sparks can be created from plugging in or unplugging an electrical supply cord or from the static electricity generated by the flow of fluid through the pump and hose.

Every part of the equipment must be properly grounded to prevent static electricity from generating a spark and causing the pump or system to become hazardous. These sparks can cause a fire, explosion, property and equipment damage and serious bodily injury. Ensure that the pump and all components and accessories are properly grounded and that electrical supply cords are not plugged in or unplugged when these hazards exist.

Should any evidence of static electricity (sparks or small shocks while in contact with the equipment) exist, discontinue pump operation immediately. Investigate the source of the static electricity and correct the grounding problem. Do not use the system until the grounding problem is repaired.

Grounding the pump

Always use the following procedures for grounding the pump. Loosen the lock screw to allow insertion of one end of a minimum sized 12 gauge wire into the bore hole of the grounding lug. Insert 12 gauge wire and tighten the lock screw securely. The other end of the ground wire must be secured to a true earth ground.

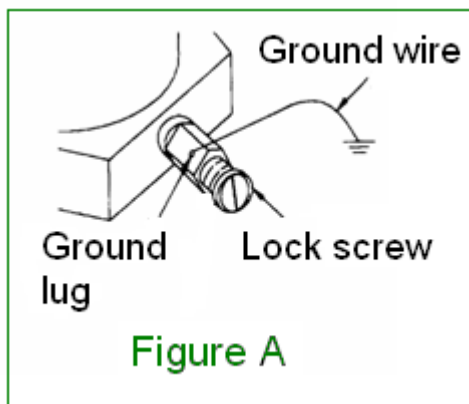

Grounding procedures

Grounding of the pump and all other dispensing equipment is necessary to minimize the possibility of sparks due to static electricity. Grounding must be in compliance with local electrical codes. Check with the local authorities for requirements in your area and with the type of equipment being used. Ensure that all the following equipment is grounded:

1. Air compressor: Follow the grounding procedures as recommended by the compressor manufacturer.
2. Air hoses: Always use grounded air hoses.

3. Fluid container used to supply the system: Grounding must be done according to local electrical codes.
4. Pump: Follow the procedures referred to in Figure A (page 6).
5. Fluid Hoses: Always use grounded fluid hoses.
6. Dispensing Valve: The valve must be metal to conduct through the fluid hose to the pump which must be properly grounded.
7. Dispensing Point: Grounding must be done according to local electrical codes.
8. Solvent Containers use only metal: Grounding must be done according to local electrical codes. conductive pails that are properly grounded.
9. Grounding while dispensing, cleaning or relieving pressure: Maintain conductivity by firmly securing the metal part of the dispensing valve to the side of a grounded metal container.

Hose grounding

It is very important that the hoses used for both air and fluid dispensing be a grounding type and that ground continuity is maintained at all times during operation. Regular checks of the hose ground resistance (with a resistance meter using a suitable range) and a comparison to the Manufacturer's Specification will ensure that the ground is within specifications. If it is not within specified limits it should be replaced immediately.

Solvent cleaning

While cleaning the system with solvent, secure the metal part of the dispensing valve in contact with a grounded metal pail to minimize the possibility of splashing/spraying of chemicals on the skin, in the eyes and around static sparks. Use low fluid pressure for additional safety.

Hazards from moving parts

Use the *Pressure Relief Procedure* (page 5) to prevent the pump from starting un-intentionally or un-expectedly. Be aware of moving parts that present a pinching hazard to fingers or other body parts. Stay clear of these moving parts at all times when starting or operating the pump.

Safety standards

Safety standards have been established by the United States Government under the Occupational Safety and Health Act. These standards should be consulted as they apply to the hazards and type of equipment being used.

2.0 INSTALLATION

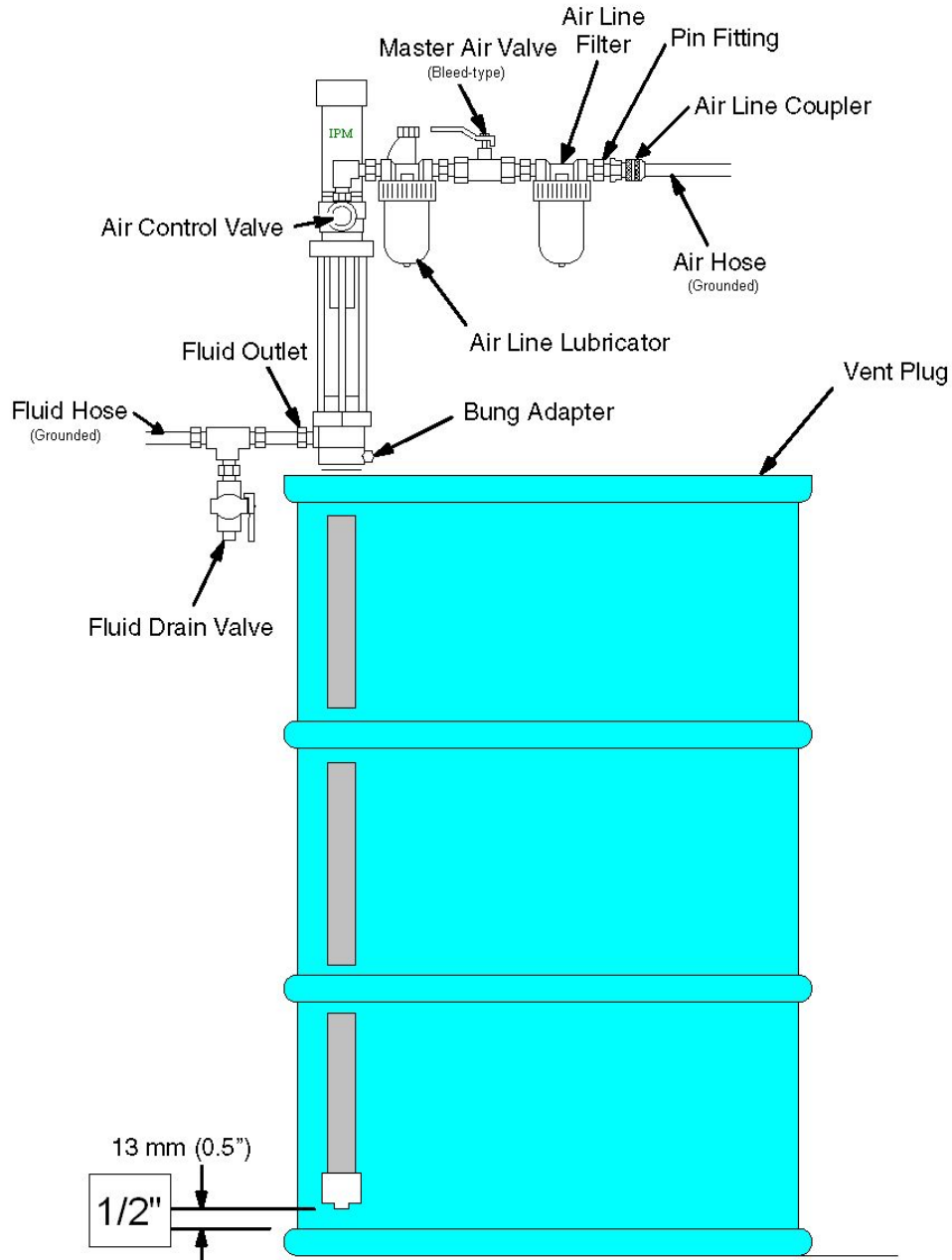

Figure B

Figure B depicts only a typical installation providing a guide for your reference but many other installation methods can be used based on your specific application. Some parts shown are not included but are sold separately. Feel free to call your **Local Distributor** for assistance.

2.1 Installation procedures

Install the necessary accessories in sequence using **Figure B** (page 8) as a guide. An air control valve (IPM part #601805) for controlling air flow is required. To minimize the risk of serious injury such as splashing/spraying chemicals on the skin, in the eyes or injury from moving parts, install the following accessories in your system.

1. **Bleed-off master air valve**

This valve will relieve the air trapped in the system after pump operation is ceased. Air that is trapped between this valve and the pump can cause the pump to reciprocate un-intentionally or un-expectantly and may cause injury to the operator.

2. **Fluid Drain Valve**

The fluid drain valve is installed to relieve fluid pressure in the pump, hose or at the dispensing valve when pump operation is ceased. The relief of pressure by the dispensing valve, which at times is inadequate if there is a clog or other restriction in the hose or dispensing valve can be achieved by using this fluid drain valve. Always use a metal valve for grounding purposes.

Lubrication

Connect an air lubricator to help achieve maximum pump longevity. The in-line lubricator provides proper lubrication to the air motor during operation. (see daily maintenance check, page 14). Next, install a bleed-off master air valve on the system. This valve is required on your system to relieve trapped air as explained above.

Air filters help to remove dirt and foreign particles from the supply air. Water moisture will also be trapped within this filter. Be sure to release the trapped water daily as a good maintenance practice (see daily maintenance check, page 14). Connect a grounded air supply hose for main air supply.

For the fluid section, connect one fluid drain valve directly after the outlet of the pump. Be sure to connect it pointing downwards for safety. Connect a grounded fluid hose to the fluid outlet 3/4" NPT (female).

Ensure that installation is fully completed before proceeding with start up operations.

Ensure grounding of the pump and accessories is completed before beginning pump operation. Observe all OSHA and other safety regulations.

2.2 Additional mounting configurations

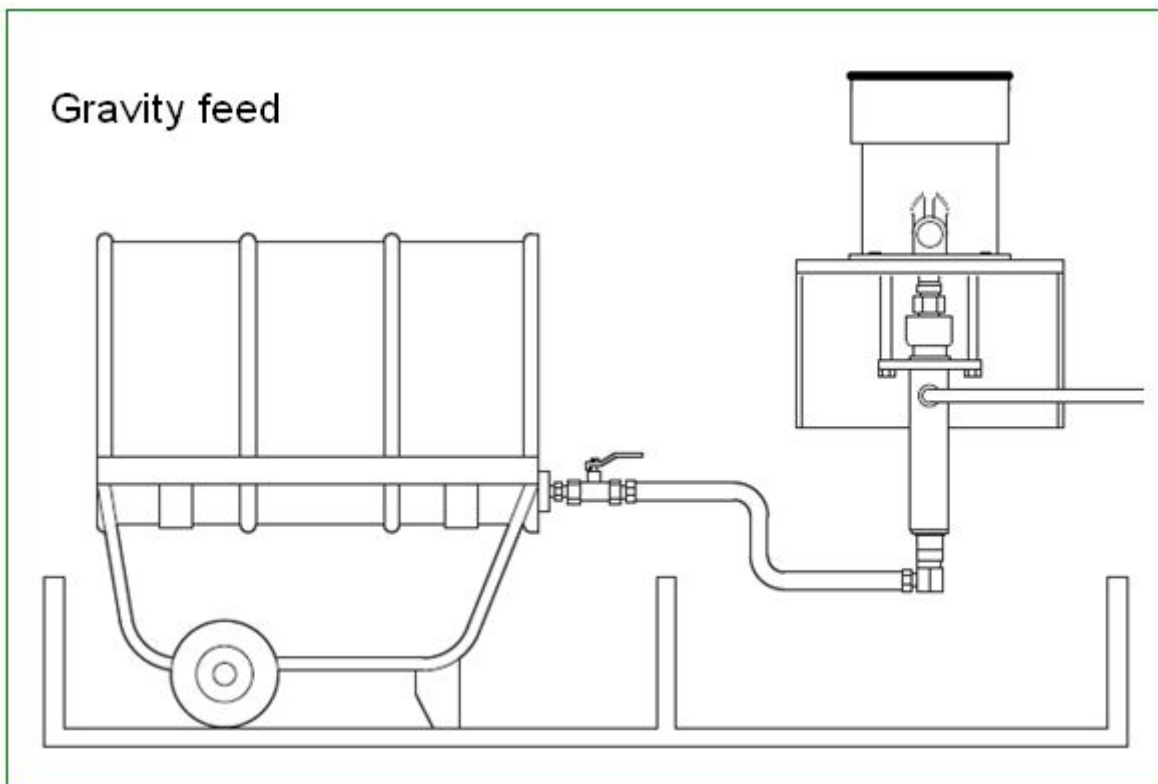
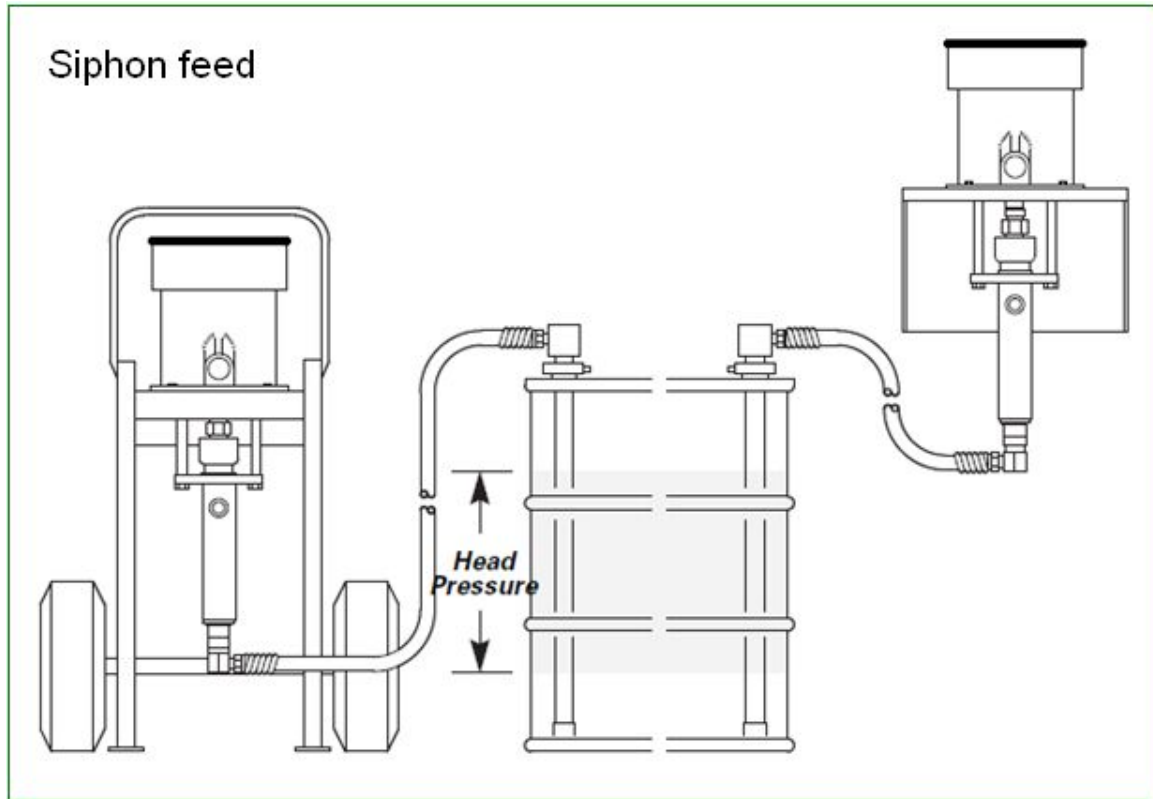

Submersion feed

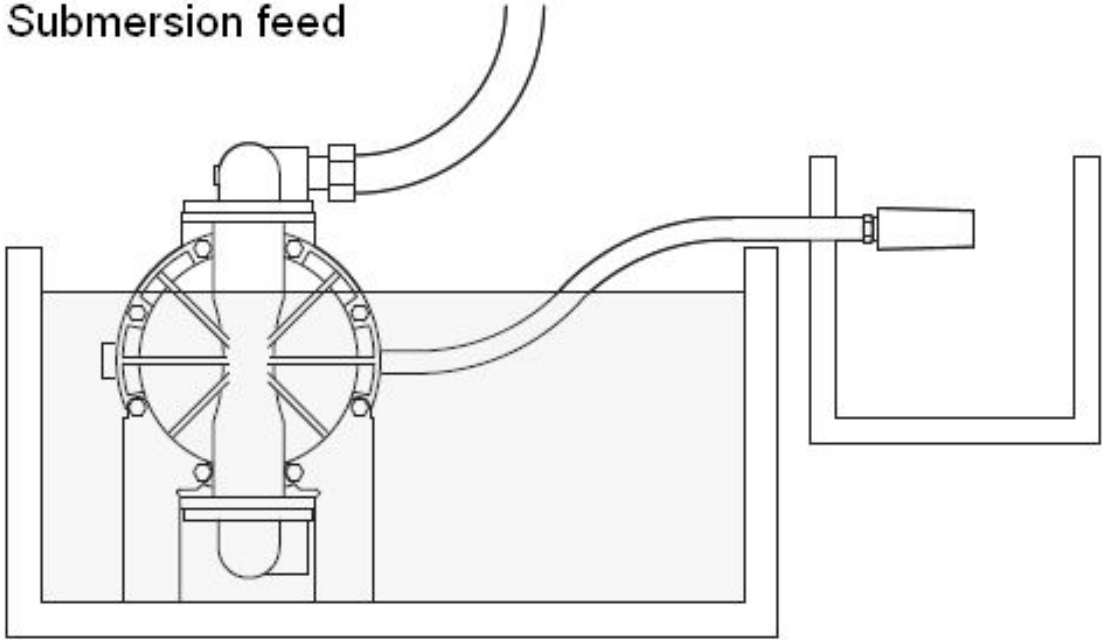

Pressure feed

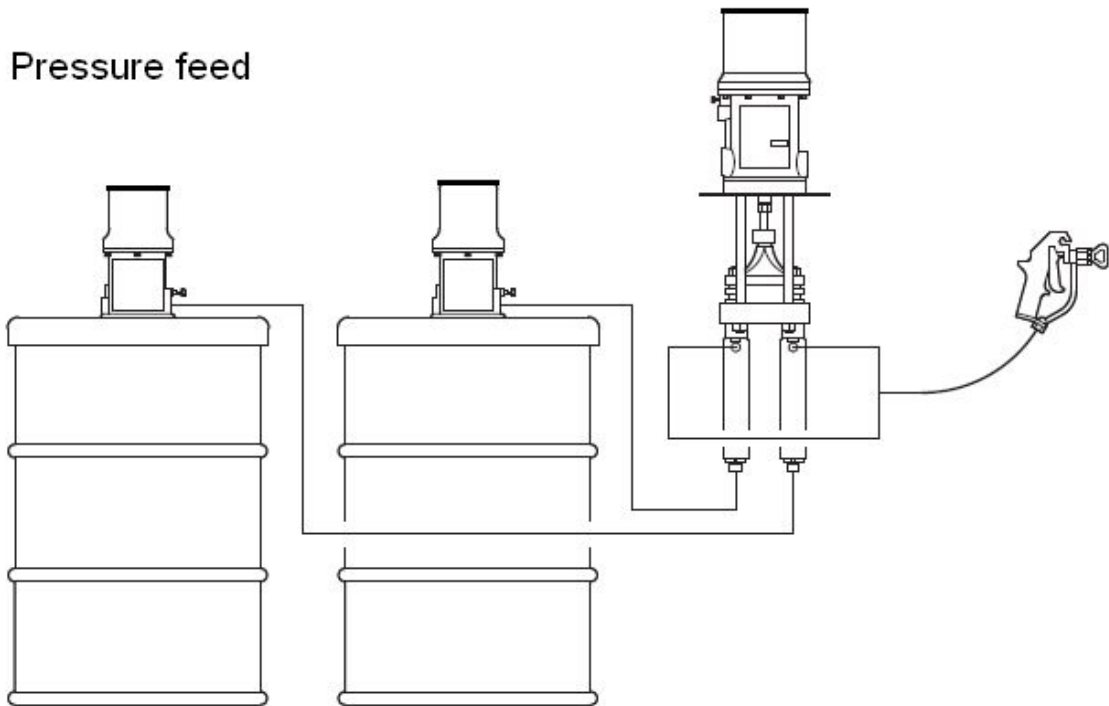

2.0 OPERATIONS

3.1 Working principle of transfer pump

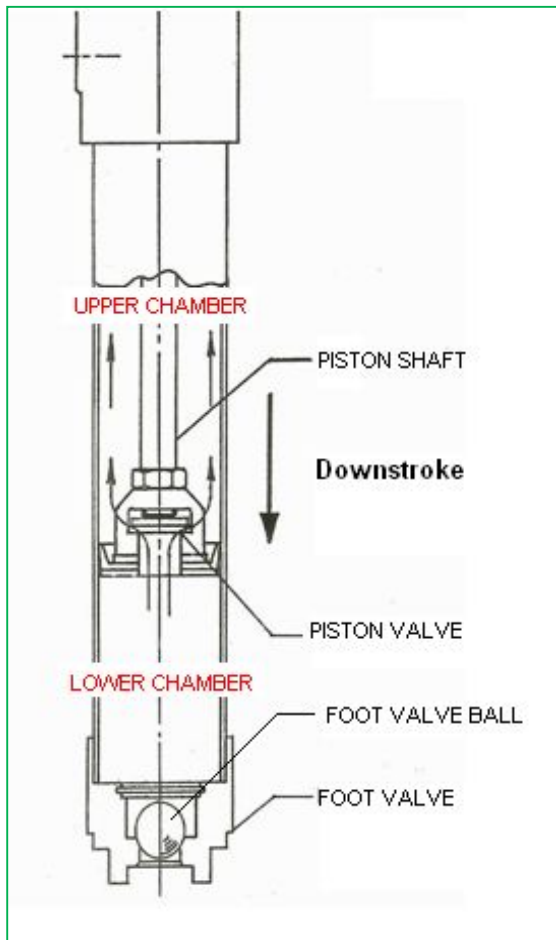

Downstroke: When the PISTON SHAFT is in the downstroke motion, the fluid that is present in the lower chamber of the cylinder moves the FOOT VALVE BALL into the closed position. The entrapped fluid then lifts the PISTON VALVE up as it flows into the upper chamber and to the fluid outlet in **Figure B** (page 9).

Upstroke: During the upstroke motion, the PISTON VALVE is closed and fluid present in the upper chamber is transferred to the outlet port. At the same time, the FOOT VALVE BALL is opened by incoming pressure and fluid is then drawn into the lower chamber.

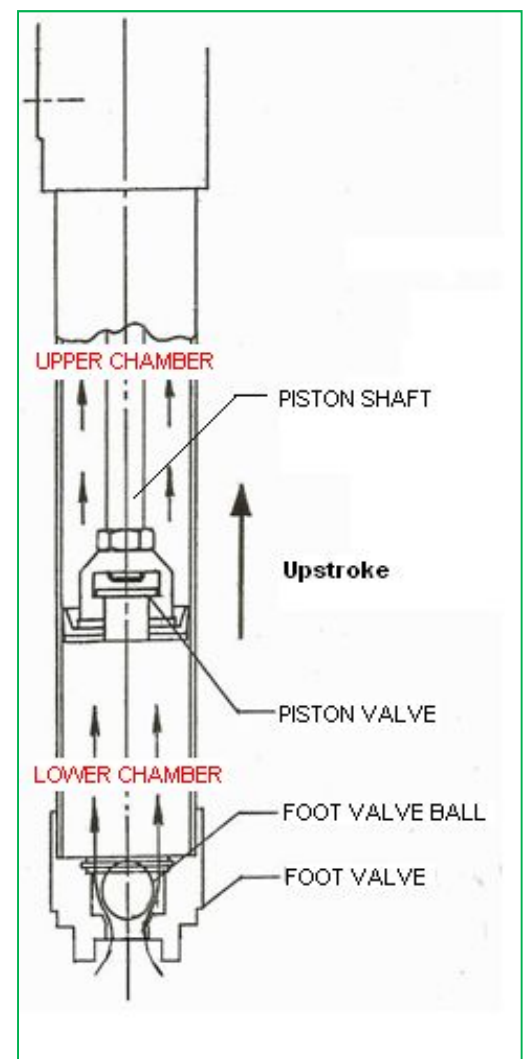

3.2 Start up and adjustment of transfer pump

1. Ensure that the air control valve is closed then open the bleed-type master air valve. Connect the quick disconnect coupler to the male fitting.
2. For safety, open the dispensing valve slowly, then drain fluid into a grounded metal container. Ensure metal-to-metal contact is maintained between the container and the valve at all times.
3. Adjust the air control valve slowly for just enough pressure to start running the pump. This is to prime all air within the system. After all the air has been expelled from the lines, close the dispensing valve. During the priming of the pump, the pump operates when the dispensing valve is opened and stops when the valve is closed.
4. Turn the air regulator slowly until sufficient flow from the dispensing valve is achieved. Remember to always run the pump at the lowest possible speed necessary to achieve what is desired. Never exceed the maximum working pressure of any component in the system.
5. The pump should not be left to run dry of the fluid being worked upon. When running empty, the operating speed will rise rapidly, increasing the chance of damage to the pump and/or components. During operation should the pump be found to run too fast, stop it immediately and ensure the fluid supply is not too low or the drum is empty. If air has gone into the system, repeat the priming procedure. Ensure that all air has been expelled from the lines before beginning operation again. Flush the pump or leave it filled with a compatible solvent when not in use.
6. Always follow the Pressure Relief Procedure should the pump be put away for any period of time or during system shut off at the end of the day.

3.3 Shut down procedure

1. Relieve the air pressure with the air regulator.
2. Open the air needle valve.
3. Bleed off residual pressure in the system with the bleed-off master air valve.
4. Open the drain valve to relieve fluid pressure in the system. Use a container to collect the fluid drained off. **Be especially careful as the fluid may still be under pressure.** Hold the metal fluid drain valve against the side of the grounded container while relieving the pressure.

Note: For long periods of shut-down, flush the pump thoroughly with an appropriate cleaning fluid to prevent solidified chemical build-up.

3.4 Daily maintenance check

1. Ensure sufficient lubricant in the air lubricator.
2. Keep the packing cup $\frac{1}{2}$ filled with a suitable fluid to ensure the piston rod remains clean and lubrication is supplied to the packing.
3. Drain any moisture trapped in the air pressure cylinder.

Note: Clean and flush the pump thoroughly with appropriate cleaning fluid to maintain the maximum service life of the equipment.

3.5 Disassembly procedure

1. All inlet/outlet hoses should be removed and the pump moved to a suitable work area.
2. Clamp on the outlet housing with the outlet hole against one of the jaws of the vice. Alternatively, a pipe clamp may be utilized instead of a vice. When clamping the housing, it becomes possible to remove either the air cylinder or the lower tube and/or foot valve.



3. Remove the foot valve, while holding the air cylinder with a strap wrench as shown.

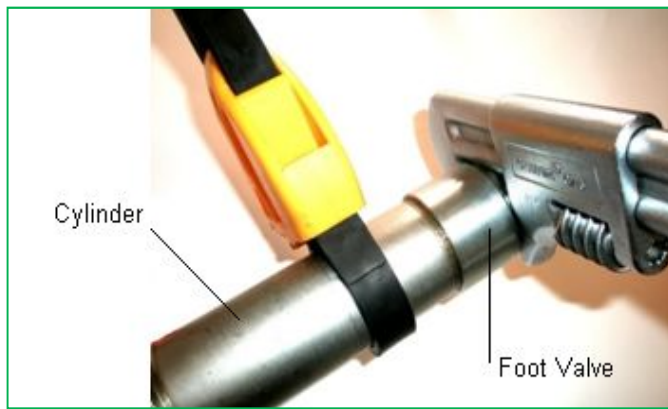

4. Use snap ring pliers to remove snap ring and E-clip. Remove check ball and examine foot valve for debris and/or damage. Replace as necessary. Replace Teflon O-ring and re-assemble foot valve with ball, snap ring and E-clip.

A NOTE ON FOOT VALVES: All foot valves have been converted to a higher flow capacity. This is a design element to reduce out-gassing and suction pressure within the pump. While the foot valves are readily interchangeable with the older style the internal components are not, so take care when ordering replacement parts.

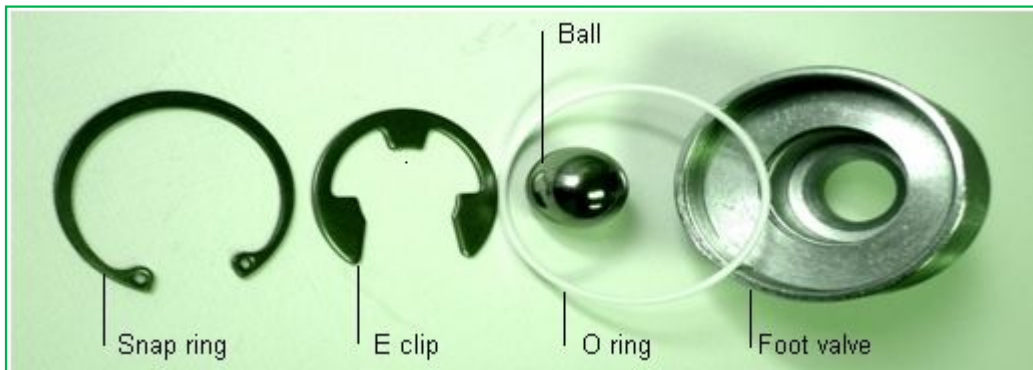

5. With a strap wrench close to outlet housing, unscrew the air cylinder taking care NOT to bend the piston rod in the process. Examine air cylinder for damage to the interior cylinder wall by looking through the cylinder at an acute angle to a light source.

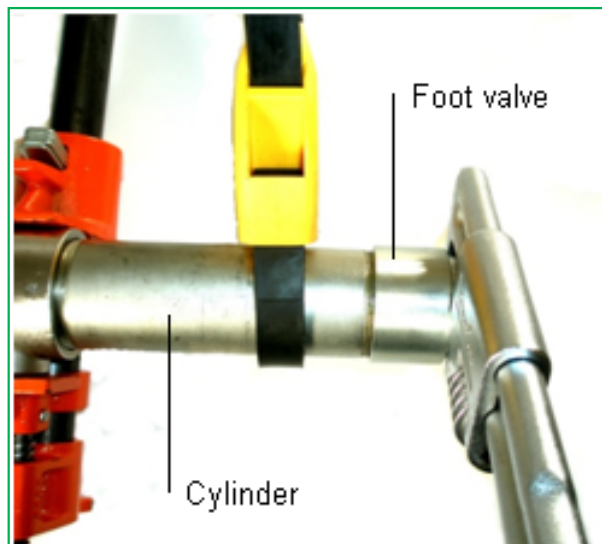

- At this point you can remove either the connecting rod from the displacement rod or the internal check valve from the connecting rod. Typically, you will be taking apart the internal check valve assembly to inspect and clean.

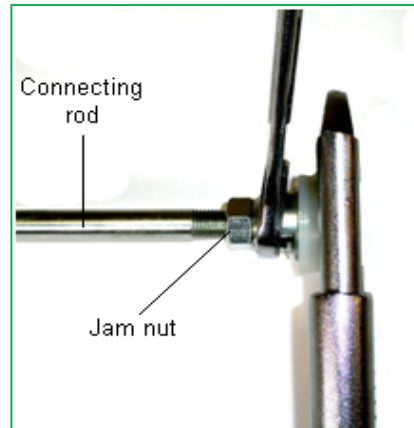

- Please note that you must loosen the hex nuts and re-tighten upon assembly.
- Carefully clamp piston valve housing in vice and unscrew piston pump. Remove the piston cup and examine for damage; replace if necessary. Check piston valve within the piston valve housing for build up, debris or damage.
- Re-assemble the piston pump to the piston valve housing with the piston valve, washer and piston cup in place. Shown in the picture below are the components for the upper check valve.

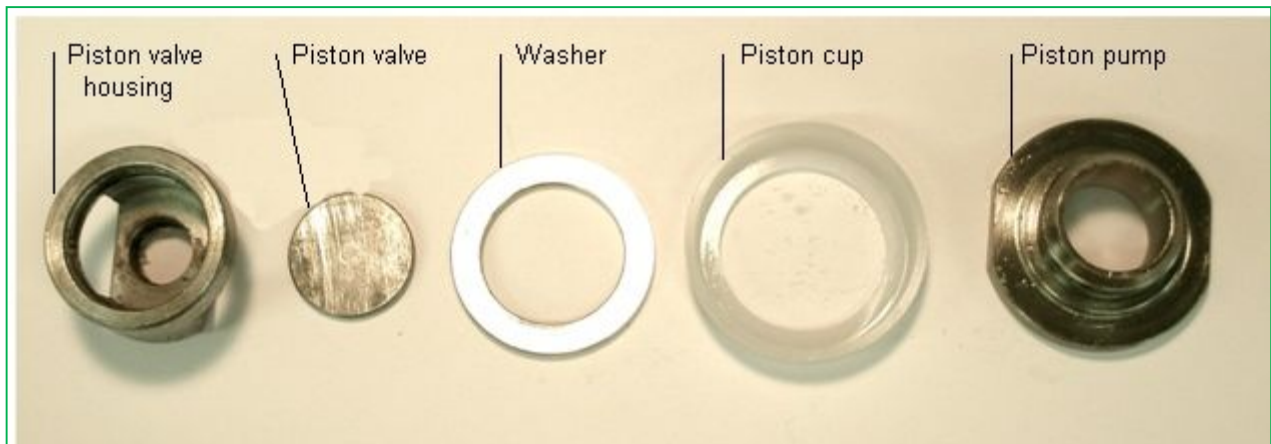

- Re-assemble the hex nut onto the connecting rod. Install the piston valve housing assembly onto the connecting rod. Adjust the piston valve housing so that the tolerance between the connecting rod and the piston valve is between 0.060" and 0.080" using a feeler gauge for accuracy. **This gap is extremely important because too much gap will not allow the fluid to flow correctly; too little or no gap will restrict the flow.**
- From the fluid section, remove the three lock nuts from the three tie rods. Slide complete air piston assembly out through the outlet housing. Complete air motor assembly (IPM part #700014) is shown in "4.0- Parts diagram for all pumps."

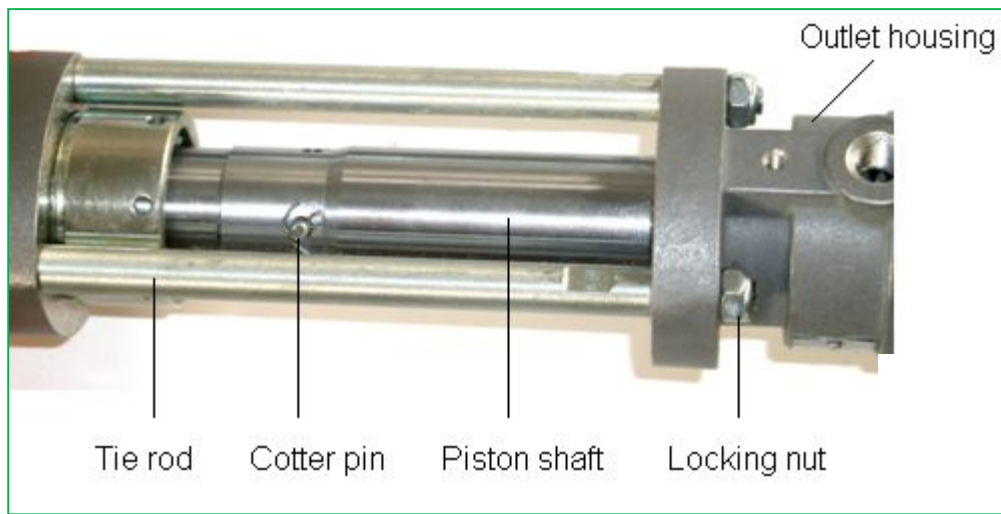

12. From the air motor section, remove the cotter pin then remove the flat head pin. Unscrew the displacement rod from the piston shaft, as shown in diagram above.
13. From the air section, remove the packing nut from the outlet housing and remove female gland, male gland and "V" block packing from the outlet housing. Examine all packing's for damage and replace if necessary. Examine the displacement rod for damage along its length and on both ends. Replace if necessary. Lubricate then re-assemble the packing parts (female gland, male gland and "V" block packing) onto the outlet housing. Tighten up the packing nut taking care not to over-tighten it to ensure no damage occurs to the packings.

14. Clamp the air motor assembly in a vice by the air motor base. Using a strap wrench near the base as shown, remove the air cylinder. Examine the conical spring in the air motor cap to ensure that it is not damaged or loose. Slide the air motor assembly with the piston shaft out through the air motor base. Examine the V-block packing for damage and replace if necessary. Examine the square cut gaskets in the air motor cap, top and bottom and replace if needed. This gasket seals the cylinder cap to the air cylinder. Look at air section illustration for a complete parts reference numbers.



15. From fluid section, unscrew displacement rod from the piston shaft. Examine for debris build-up or damage. Re-assemble the muffler with the point of the cone facing up inside the piston shaft. Screw the displacement rod into the piston shaft.
16. From air section, remove the air motor assembly from the piston shaft. Remove the three socket head cap screws. Examine the three small O-rings and one large O-ring and replace if necessary.

3.6 Assembly procedure

1. Align air motor assembly with parts seen in the component list picture below. The air exhaust valve plate and the screws require the use of Loctite-222 to ensure they do not vibrate loose during pump operation. Tighten the screws to a tolerance of 10-14 inch pounds.

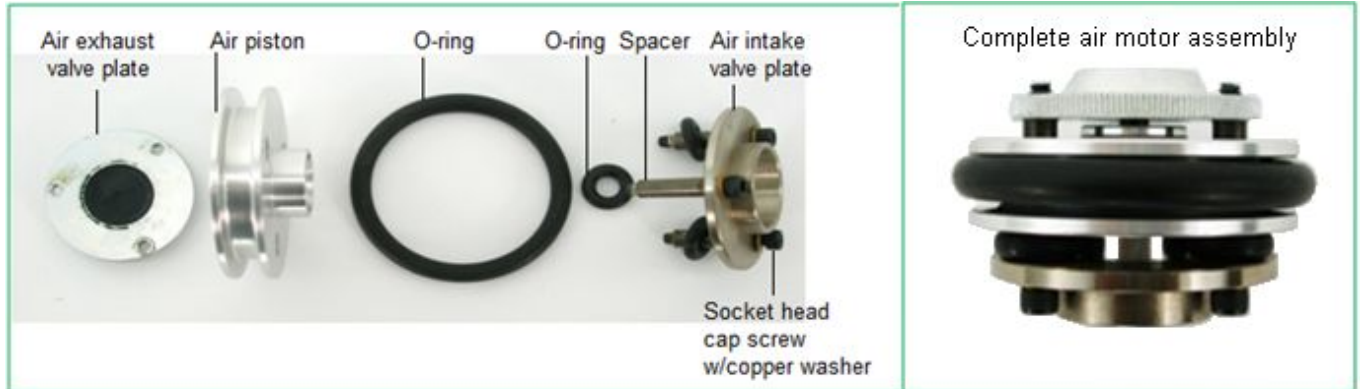

4. Assemble the complete air motor assembly again using Loctite-222 with washer onto the piston shaft. Hand-tighten only.
5. Slide complete air motor and shaft assembly into the air motor base. Ensure the two square cut gaskets are in the correct position in air cylinder and air cylinder cap. Clamp the air motor base in a vice and use a strap wrench to assemble the air cylinder and the air cylinder cap to the air motor base. Hand-tighten the air cylinder cap and connect piston shaft to displacement rod with flat headed pin, then secure with cotter pin. Install tie rods in outlet housing. Insert piston shaft through the packing's and secure the three lock nuts with Loctite-242, then torque to 8 inch pounds tolerance.
6. Secure suction piston assembly to displacement rod by screwing until the threads bottom-out on the hex nut then re-tighten the hex nut.
7. Replace O-ring in outlet housing. Use Loctite-222 on threads for air cylinder and screw into outlet housing. Hand-tighten air cylinder in place.
8. Use Loctite-242 on the threads exposed on the cylinder and tighten foot valve in place.

4.0 2011 IPM PUMP IDENTIFICATION LIST

Part #	Description
810101	Drum length Carbon steel 1:1 transfer pump
810102	Stubby length Carbon steel 1:1 transfer pump
810103	Drum length Stainless steel 1:1 transfer pump
810104	Stubby length Stainless steel 1:1 transfer pump
810105	Pail length Carbon steel 1:1 transfer pump
810201	Drum length Carbon steel 2:1 transfer pump
810202	Stubby length Carbon steel 2:1 transfer pump
810203	Drum length Stainless steel 2:1 transfer pump
810204	Stubby length Stainless steel 2:1 transfer pump
810206	Drum length Stainless steel 2:1 transfer pump Pressure Relief
810207	Stubby length Stainless steel 2:1 transfer pump Pressure Relief
820301	Drum length Stainless steel 2:1 transfer pump
820302	30 GAL. drum, 3/4 length stainless steel 2:1 transfer pump
820303	Low ceiling, drum length Stainless steel 2:1 transfer pump
820304	Wall mount, Stubby length Stainless steel 2:1 transfer pump
820306	Drum length stainless steel 2:1 transfer pump
830802	Drum length Stainless steel 5:1 transfer pump
830803	Stubby length Stainless steel 5:1 transfer pump
840902	Drum length Stainless steel 10:1 transfer pump
840903	Stubby length Stainless steel 10:1 transfer pump
841001	Stubby length Stainless steel 15:1 transfer pump
841101	Stubby length Stainless steel 30:1 transfer pump

5.0 PARTS IDENTIFICATION

5.1 Parts drawing for air motor section Pump # 810101

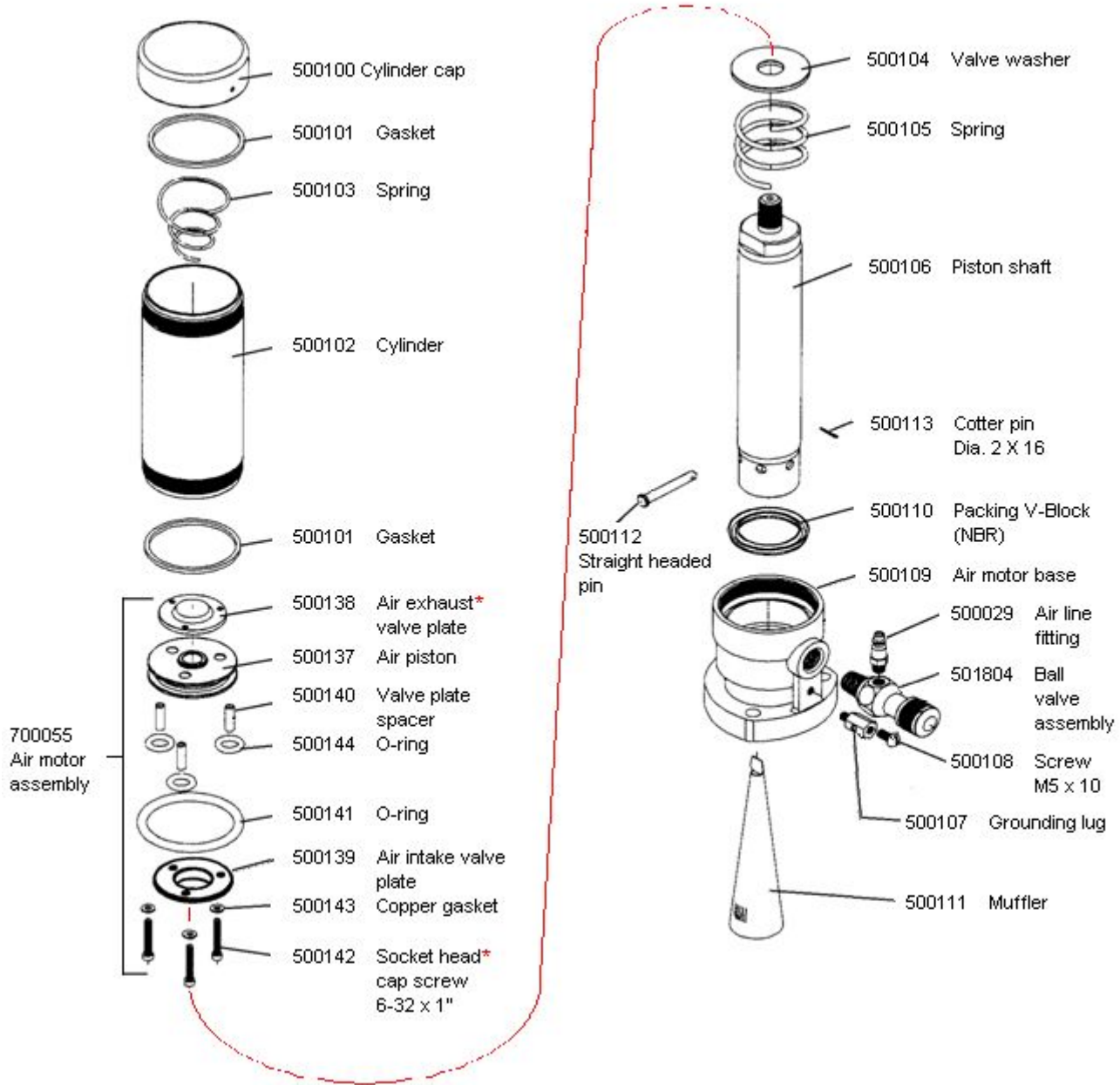

**700045 Complete
air motor
section**

* Part number 500142 (threads) and part number 500138 require the use of T200003 Loctite to help ensure they do not come undone.

5.2 Parts drawing for fluid section Pump # 810101

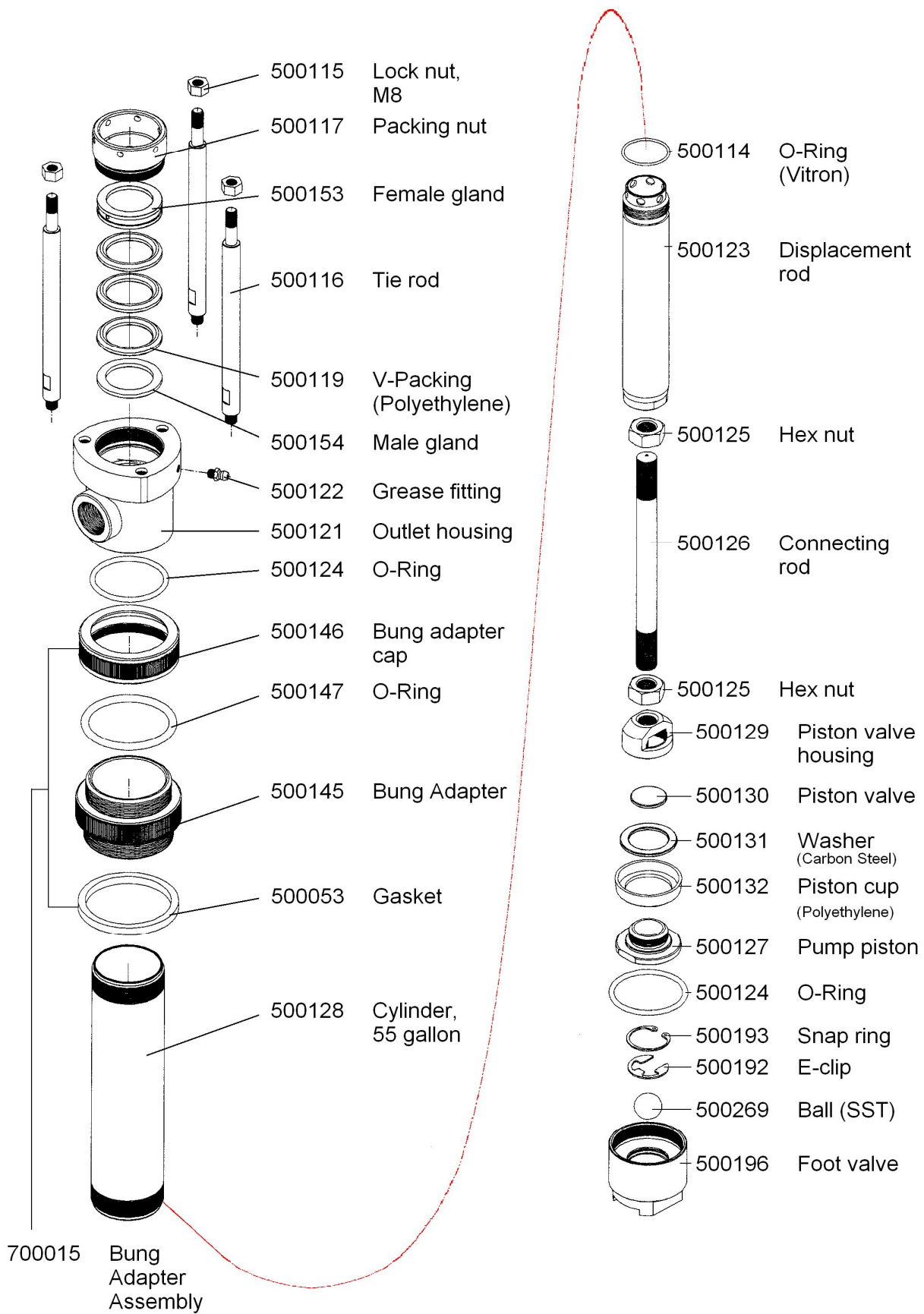

5.3 Parts Drawing for air motor Section Pump # 810102

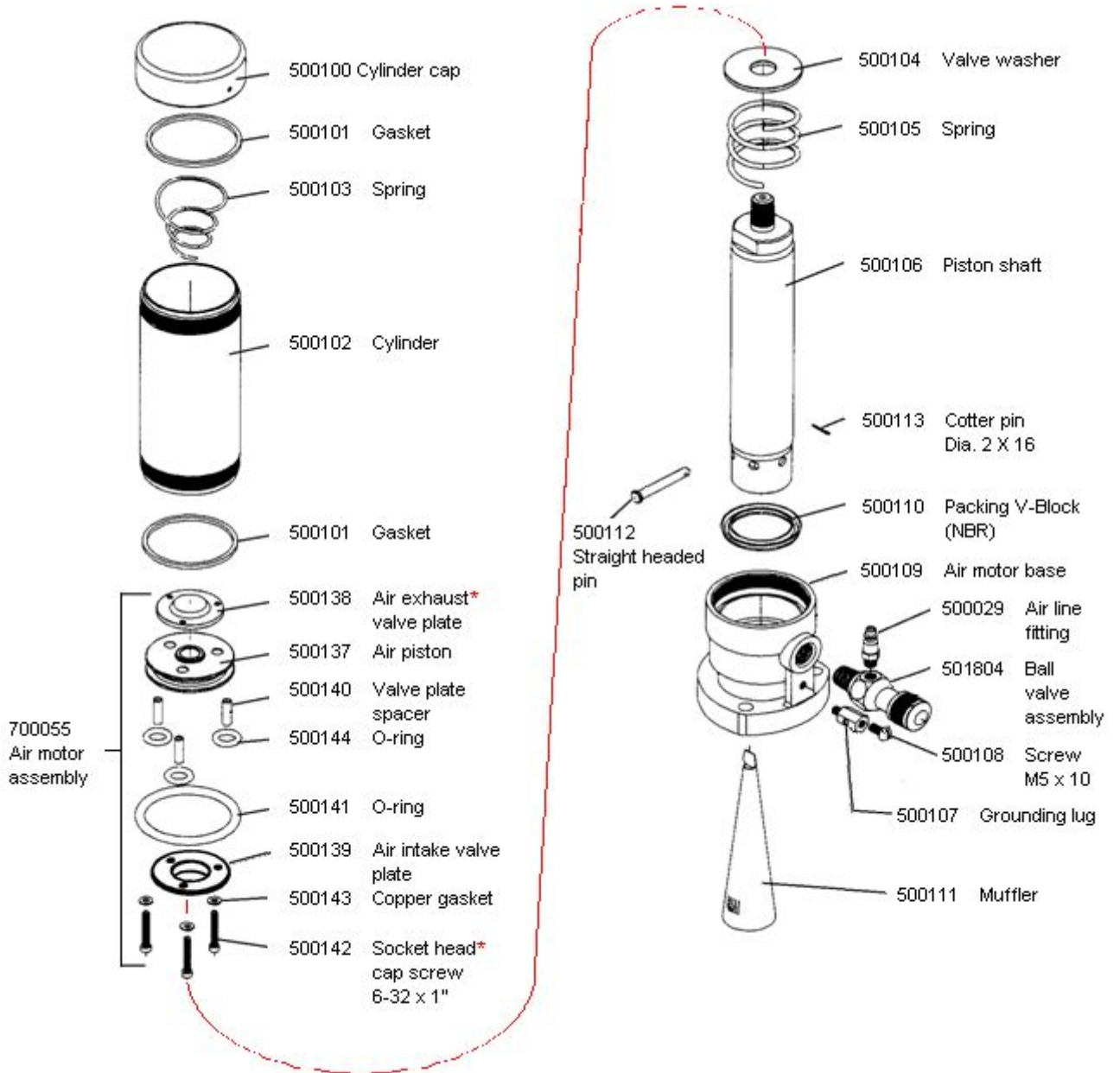

700045 Complete air motor section

* Part number 500142 (threads) and part number 500138 require the use of T200003 Loctite to help ensure they do not come undone.

5.4 Parts drawing for fluid section Pump # 810102

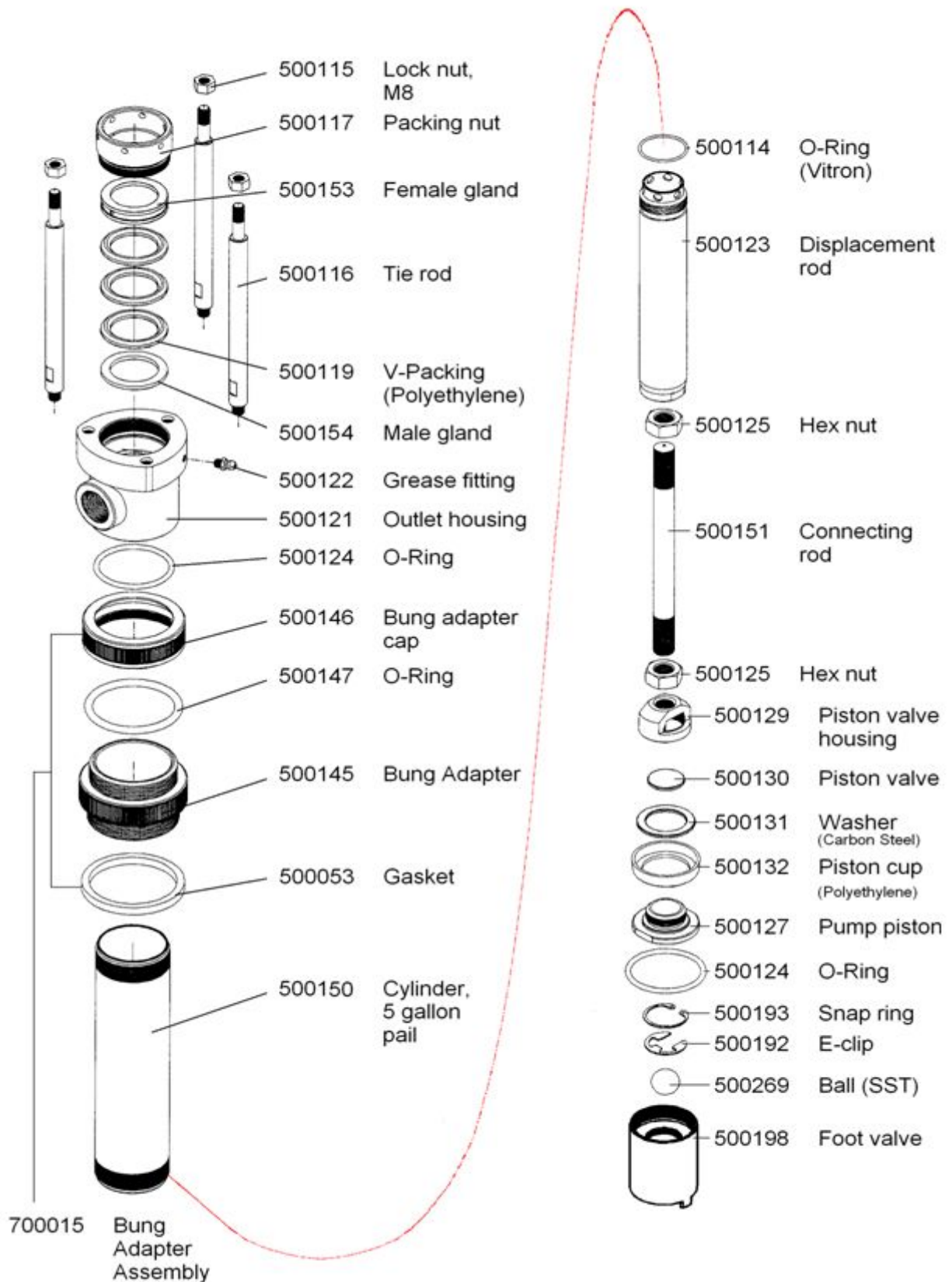

5.5 Parts drawing for air motor section Pump # 810103

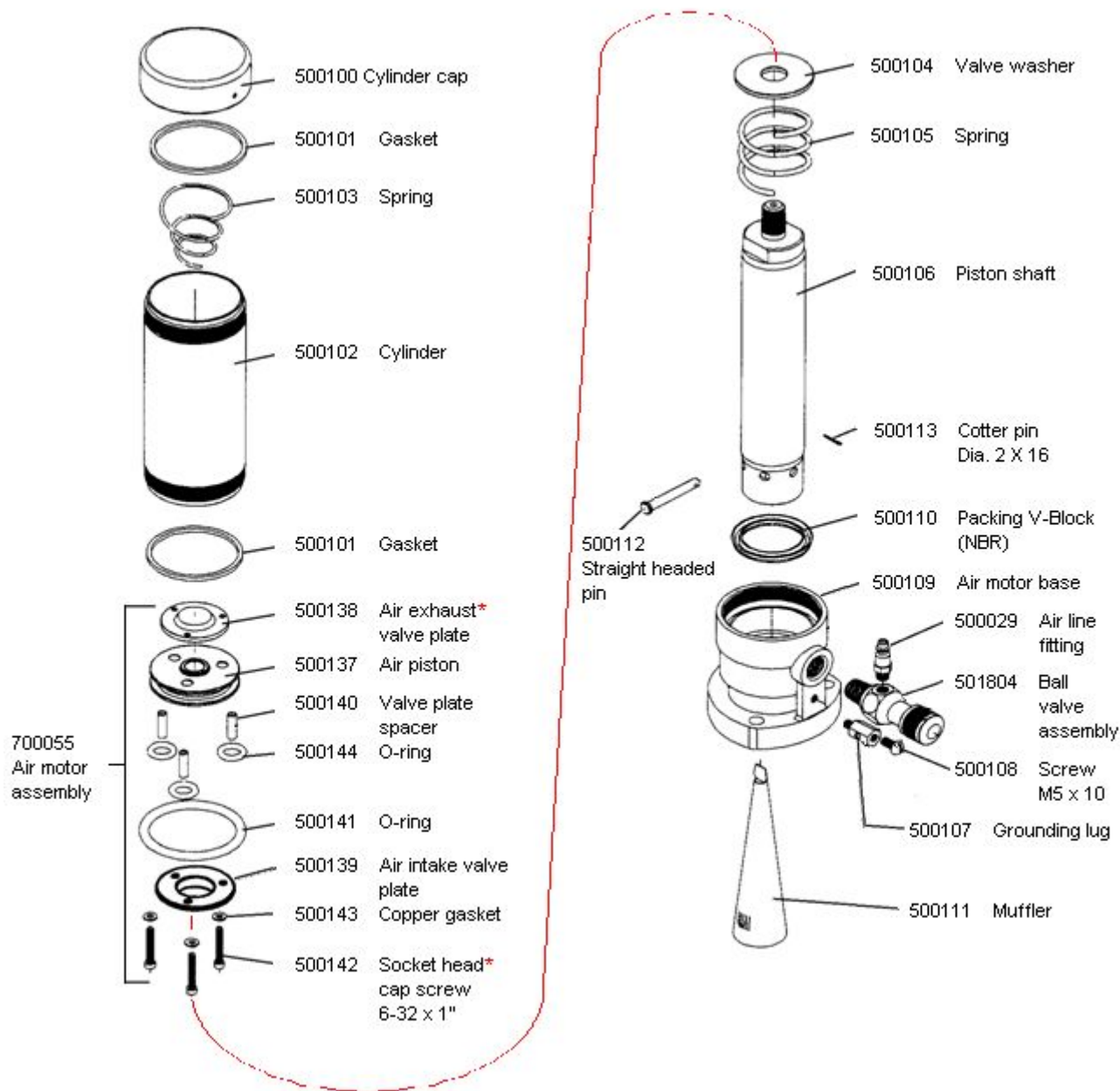

700045 Complete air motor section

* Part number 500142 (threads) and part number 500138 require the use of T200003 Loctite to help ensure they do not come undone.

5.6 Parts drawing for fluid section Pump # 810103

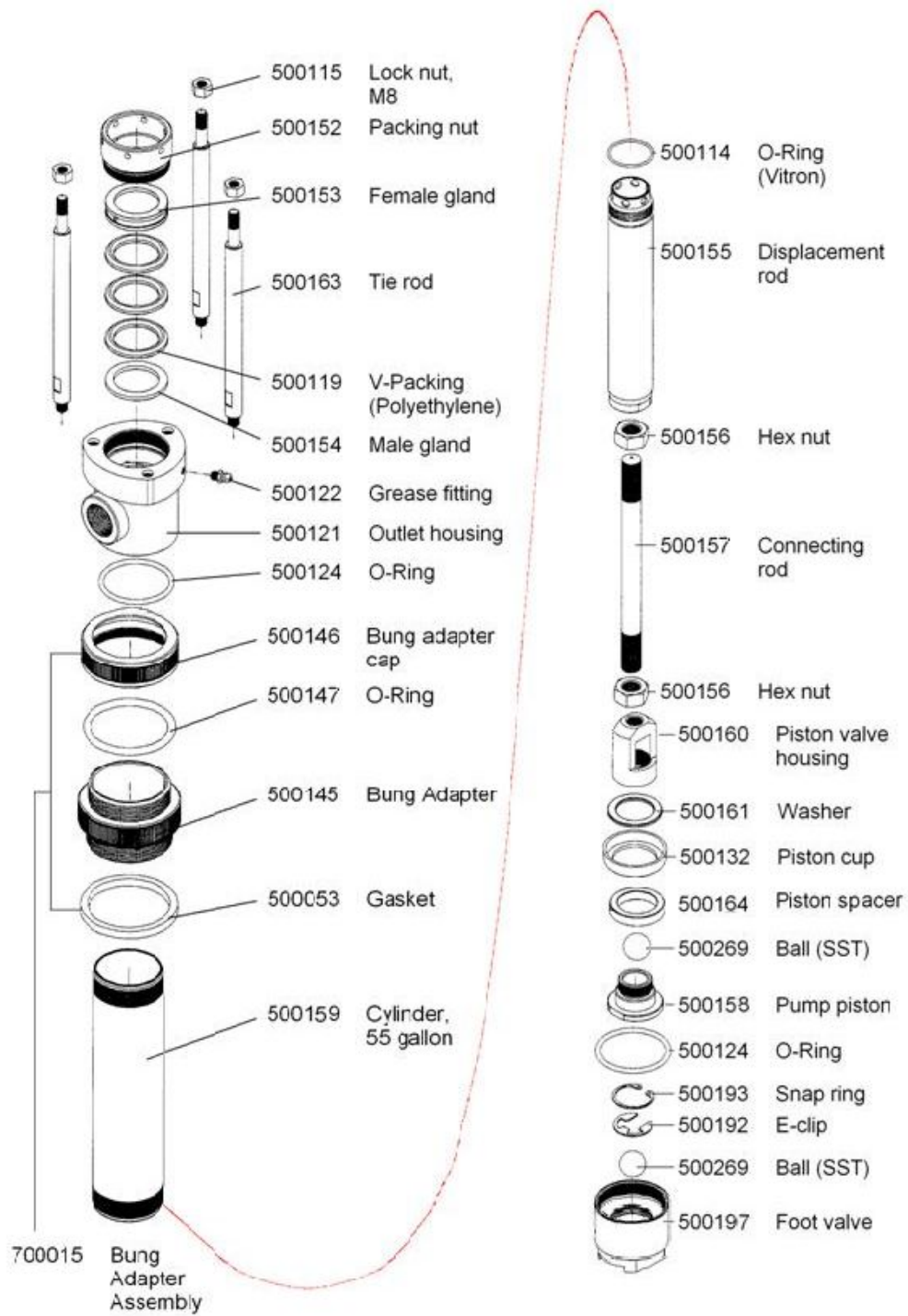

5.7 Parts drawing for air motor section Pump # 810104

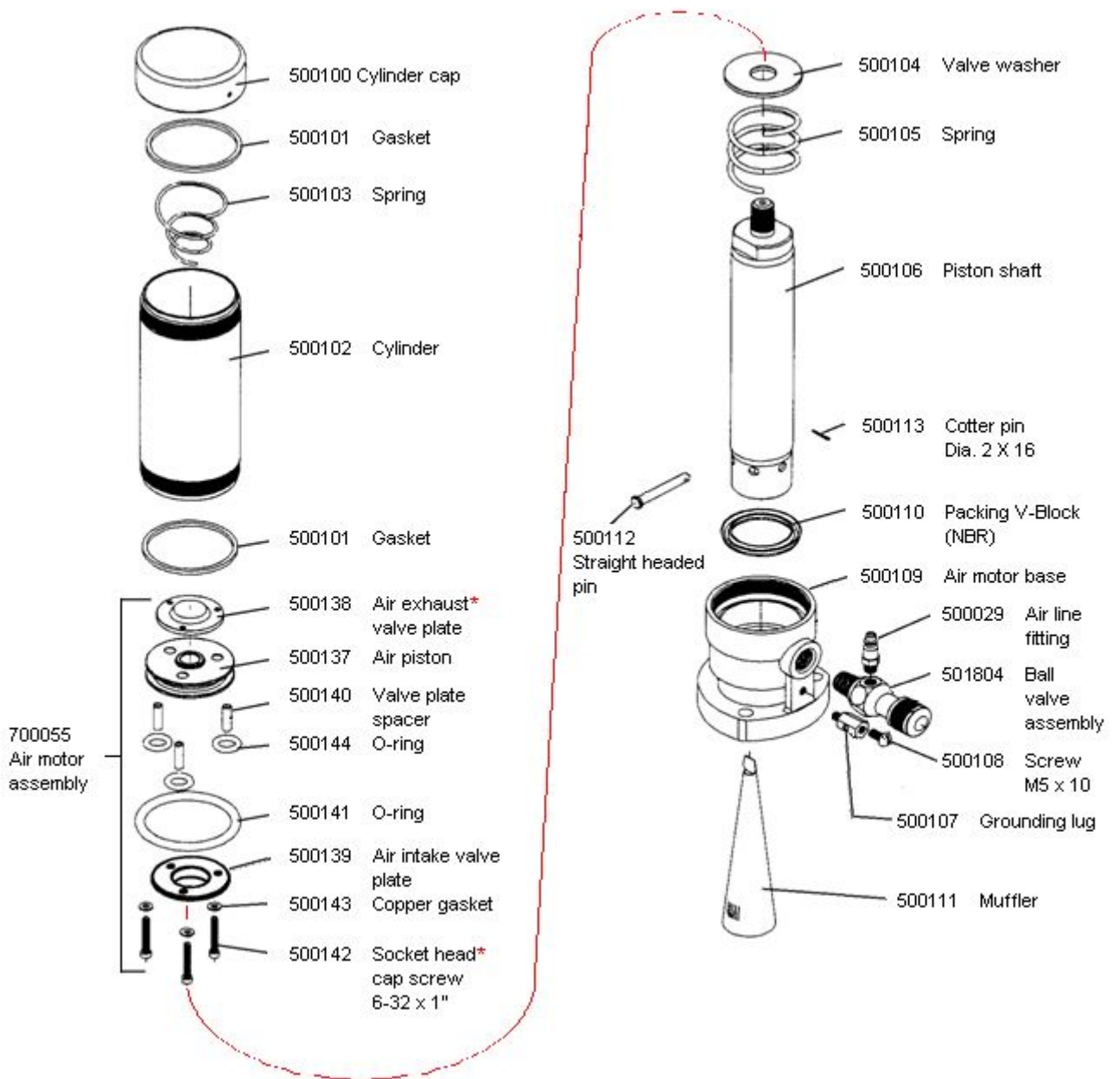

**700045 Complete
air motor
section**

* Part number 500142 (threads) and part number 500138 require the use of T200003 Loctite to help ensure they do not come undone.

5.8 Parts drawing for fluid section Pump # 810104

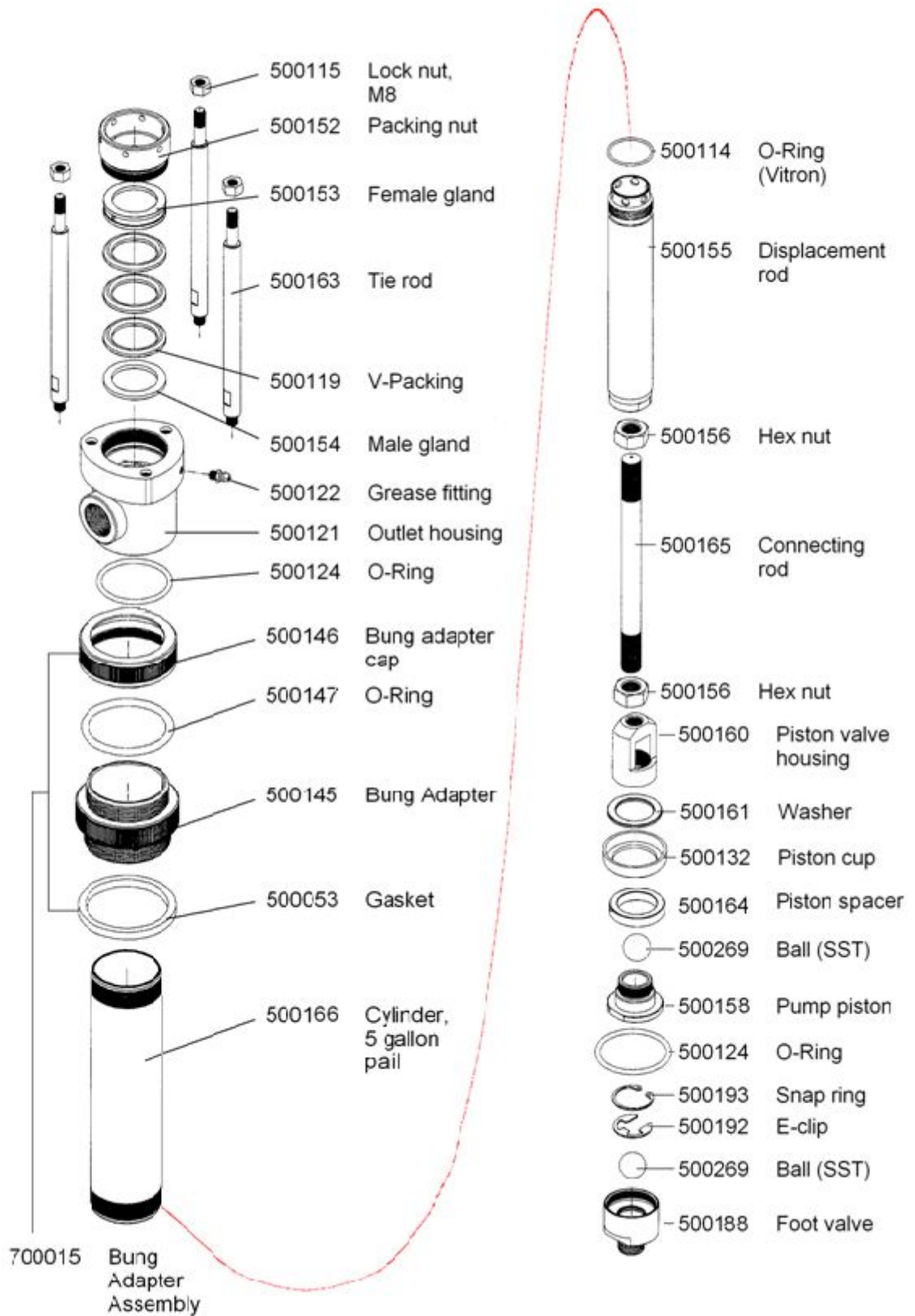

6.0 REPAIR KITS

IP01 Series - 1:1 pump repair kits

601005	Air section repair kit		
	Fits: 810101, 810102, 810103, 810104, 810105		
	Components include		
	Part #	Description	Qty
	500101	NBR gasket	2
	500110	NBR "V" block packing	1
	500141	Viton O-ring	1
	500144	Viton O-ring	3

601004	Fluid section repair kit, Teflon package		
	Fits: 810101, 810102, 810103, 810104, 810105		
	Components include		
	Part #	Description	Qty
	500153	Female gland	1
	500154	Male gland	1
	500180	Teflon "V" block packing	3
	500181	Teflon Piston cup	1



601006	Fluid section repair kit, UHMW PE package		
	Fits: 810101, 810102, 810103, 810104, 810105		
	Components include		
	Part #	Description	Qty
	500119	"V" block packing	3
	500132	Piston cup	1
	500153	Female gland	1
	500154	Male gland	1

7.0 TROUBLE SHOOTING

Problem	Cause	Recommended Solutions
Pump does not move	Air motor stalled	Remove and then reattach the quick disconnect fitting to re-start the air motor.
	Fluid section seized	Make sure the pump has no air or liquid pressure. Remove air cylinder and cap from air motor. See if the piston rod can move up/down or turn. If yes, check for full stroke ability. If piston rod does not move at all, the fluid section is seized.
	Low air supply	A) Increase air supply B) Open air ball valve C) Close bleed valve
Air leak along piston shaft.	Worn packing in fluid section.	Replace packing
Air leaks from piston shaft holes.	Contamination by debris in the air motor piston.	Check O-ring, replace if necessary. Also check the rubber seal to see if it has come apart from the air exhaust valve plate.
Slow operations (Air Motor)	Icing of the air motor. Clogged muffler.	Allow ice built up on the air motor to thaw. Clean or replace the muffler.
Low output both stokes	Restricted fluid hoses. Bad fluid seal in the foot valve or defective piston cup.	Clean, clear or replace hoses. Replace ball and/or piston cup in fluid section.
Low output on up stroke	Bad or damaged piston cup.	Replace piston cup in the fluid section.
Low output on down stroke	Bad or damaged foot valve or ball.	Replace foot valve ball in the fluid section.
Leaking fluid through the packing at air motor base.	Packing damaged or not seated properly. Packing nut too loose. Scored or scratched displacement rod.	Replace packing in the fluid section. Tighten packing nut Replace displacement rod.
Abnormal or rapid operation.	Low or no fluid supply. Broken spring(s) in air motor.	Replenish fluid supply and re-prime the pump. Replace springs in the air motor.
Jerky movement of the pump	Packing nut in fluid section too tight.	Stop pump operation. Relieve fluid pressure from drain valve. Loosen packing nut and re-tighten snugly.

8.0 TECHNICAL SPECIFICATIONS

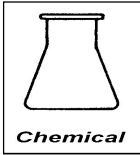
Recommended application chart

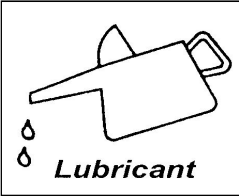
Industry	Application	Viscosity range (CPS)
 Chemical	Alcohol	0-100
	Dye	0-1000
	Methyl Chloride	0-200
	Solvents	0-500
 Surface Finishing Material	Paint(Latex)	100-1000
	Paint(Oil base)	100-800
	Sealer(Wood)	100-800
	Stain(Oil base)	100-1000
 Lubricant	Anti-Freeze	30-100
	Die Lubricant	30-50
	Gear Oil	200-1000
	Lubricant	100-1500
	Mold Release Agent	30-100
	Oil	100-500

Air pressure requirements: For optimum pump performance, 80 PSI should be supplied to the IP01 series transfer pumps.

Pump viscosity guide

All calculations in Centipoise (cps)

IP01 series pumps: 1 – 2,000 cps

IP02 series pumps: 1 – 4,000 cps

OP series pumps: 1 – 4,000 cps

IP05 series pumps: 1 – 10,000 cps

IP10 series pumps: 1 – 20,000 cps

Calculations are based on the following general guidelines

- Inbound air pressure: 100 psi
- Pressure at dispense point: 0 psi
- Hose/pipe length w/smooth inner surface = L: 25 feet
- Hose size = D: 3/4"
- Flow rate = Q: 2 gpm
- Viscosity = V:
- Pressure loss in hose/pipe (psi), P: $P = 0.0273QVL/D^4$

The above viscosity values are only general guidelines. Other factors should always be taken into consideration such as; dispensing valves, fittings, hose unions, elevation, outside ambient temperature, etc.

810101, 810102, 810103, 810104, 810105



Air Operated Fluid Pump

Technical Specifications

Fluid to Air Ratio.....	1:1
Max. Output Flow (intermittent).....	6.0 gpm (23.0 lpm)
Max. Output Flow (continuous).....	4.0 gpm (15.0 lpm)
Maximum Output Pressure.....	180 psi (12.4 bar)
Air Input Pressure Range.....	30-180 psi (2-12 bar)
Air Inlet Port.....	1/4 npt(f)
Fluid Outlet Port.....	3/4 npt(f)
Fluid Inlet Port.....	1 1/2 npt (f)
Rod & Piston Packings.....	Teflon®
Other Seals.....	Viton®
Rod & Cylinder.....	Carbon Steel or Stainless Steel
Other Wetted Parts.....	Carbon Steel or Stainless Steel
Weight stubby/drum.....	11 lbs. (4.9 Kg.)/14.3 lbs. (6.5 Kg.)
Package Dimensions & Weight:	
IP-01...4"x4"x54" (102mm x 102mm x 137cm)	22 lbs. (10 Kg.)
IP-01S...4"x4"x35" (102mm x 102mm x 889mm)	16 lbs. (7.26 Kg.)

Performance

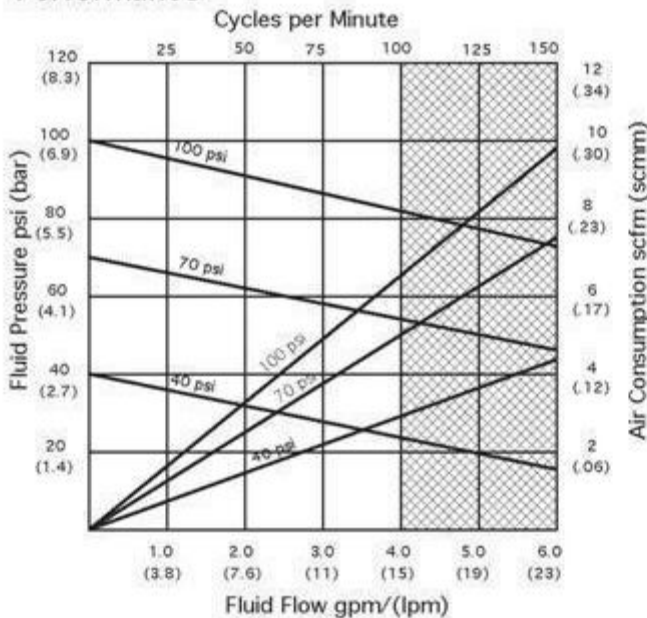

IFP 102 06/08

Dimensions

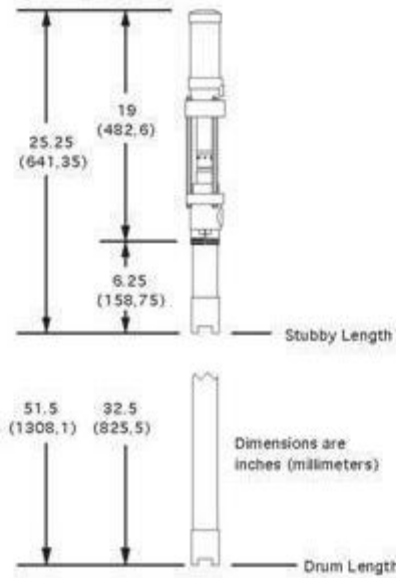

How to Read Performance

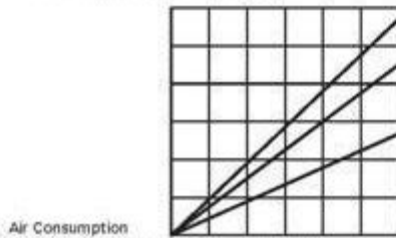
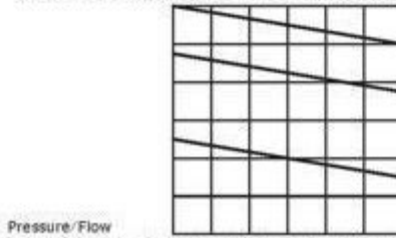

100 Series 1:1 Air Operated Fluid Pump



IPM's IP01 is a general purpose transfer pump designed for use with a wide variety of materials. The air driven motor is capable of stalling against pressure in order to maintain positive system pressure.



- Carbon steel or stainless steel construction for economy and durability
- UHMW PE packings or Teflon and Viton® seals for material compatibility

- Piston style air motor allows compact pump design, best suited for use as a drum transfer pump.
- Metal air motor and fluid housings provide more durable port threads, resistant to cross-threading.
- Modular, two-piece construction allows fast service without the need to disassemble the entire pump assembly.
- In-the-drum pump tube places the pumping chamber below the material level resulting in better suction characteristics, more complete pump filling.
- Ball check style foot valve provides superior operation especially with abrasive or contaminated materials, and delivers longer life and higher pressure operation

Typical Fluids Handled

- Isocyanates
- Polyureas
- Polyols
- Enamels
- Waterbornes
- Acid Catylyzed Finishes

Typical Applications

- SPF Insulation
- Aerospace
- Wood Furniture
- Automotive
- Transportation
- Sporting Goods



International Pump Manufacturing

Phone: 253-863-2222

FAX: 253-863-2223

Web: www.ipmpumps.com

3107 142nd Av. E. # 106

Sumner, WA 98390

10.0 WARRANTY & DISCLAIMER

WARRANTY

International Pump Manufacturing, Inc. (hereafter designated IPM) warrants the equipment it manufactures to be free of defects in materials and workmanship for a period of one (1) year from the date of sale from IPM to an authorized IPM distributor or to the original end user and/or purchaser. IPM will, at its discretion, repair or replace any part of the equipment proven to be defective. This warranty applies only when the equipment is used for the intended purpose and has been installed, operated and maintained in accordance with written operating procedures.

A condition of the warranty is the prepaid return of the equipment to an authorized distributor of IPM who shall provide verification of the warranty claim. IPM will repair or replace free of charge any parts found and verified to be defective or damaged upon receipt of equipment. Shipping will be prepaid for the repaired or replaced parts under warranty. Should inspection of the equipment reveal no defects in material or workmanship repairs will be made at the standard IPM rate, which will include parts, inspection, labor, packaging and shipping.

The warranty does not apply nor shall IPM be liable for damage, operational wear, malfunction of equipment caused by improper installation, misuse, chemical abrasion or corrosion, operator negligence, accident, tampering or altering of equipment, lack of improper maintenance and/or by substitution of non-IPM parts. Additionally, IPM shall not be liable for nor does the warranty apply to operational wear, damage or malfunction caused by incompatibility of accessories, components, structures, equipment or materials not supplied by IPM. The warranty does not apply to nor will IPM be responsible for the improper operation, maintenance, design, manufacture, installation of components, accessories, equipment or structures not supplied by IPM.

The warranty is void unless the Warranty Registration Card is properly completed and returned to IPM within ONE (1) month of the date of the sale.

LIMITATIONS AND DISCLAIMER

This warranty is the sole and exclusive remedy for the purchaser. No other warranties, expressed or implied, warranties for fitness of purpose or merchantability, or non-contractual liabilities are made by IPM, including product liability, whether on negligence or a strict liability basis. Liability for directly special or non-contractual damages or loss is expressly excluded and denied. IPM's liability shall in no case exceed the amount of the purchase price.

IPM does not warrant and disclaims implied warranties of merchantability and fitness for a particular purpose, components, accessories, equipment, materials sold but not manufactured by IPM. These parts (valves, hoses, fittings, etc.) are subject to the provisions within the warranty of the actual manufacturer of these items. IPM will provide reasonable assistance with warranty claims on these items.



3107 142nd Avenue East, Suite 106
Sumner, Washington 98390
Telephone: (253)863-2222 Fax: (253)863-2223
Website: ipmpumps.com Email: sales@ipmpumps.com

Revised: 1 June 2012